

## Letter of Notice

Construction Industry, Designers, Contractors, Building Owners

### Re: Step dimension requirements in 9.8.4.1 NBCC

The 2015 National Building Code of Canada (NBCC) is adopted in the Yukon under the Yukon Building Standards Act. The NBCC contains several provisions that apply to the construction of stairs, handrails and guards for all buildings covered by the code. Some changes were made from previous editions of the code. Permitted configurations, limitations on rise and run dimensions, information on graspable handrails and guards for part 9 buildings are a few things that can be found in 9.8 in the NBCC.

One notable change is an increase in the size of run from the 2010 to the 2015 NBCC. This change was adopted to help ensure occupant safety. The minimum run is intended to provide enough room for the stair users foot. Stairs with a run that is too small may cause users to walk sideways increasing the chance of misstep which could lead to a fall. Step dimensions can be found in 9.8.4.1 in the NBCC. with note A-9.8.4 providing illustrations explaining the different types of stair tread configurations and different stair elements. Table 9.8.4.1 speaks to Rise limitations for stair treads. Table 9.8.4.2 speaks to run limitations for rectangular treads. Both tables have different requirements for public and private stairs. Definitions of public and private stairs are attached to the tables. The illustration in note A-9.8.4 provide detail on how elements are measured on stairs.

**Table 9.8.4.1.**  
**Rise for Rectangular Treads, Tapered Treads and Winders**  
 Forming Part of Sentence 9.8.4.1.(1)

Stair Type	Rectangular Treads, <i>Tapered Treads</i> and Winders	
	Rise, mm	
	Max.	Min.
Private <sup>(1)</sup>	200	125
Public <sup>(2)</sup>	180	125

#### Notes to Table 9.8.4.1.:

- (1) Private stairs are exterior and interior stairs that serve
- (a) single *dwelling units*,
  - (b) houses with a *secondary suite* including their common spaces, or
  - (c) garages that serve a) or b).
- (2) Public stairs are all stairs not described as service stairs or private stairs.

**Table 9.8.4.2.**  
**Run for Rectangular Treads**  
 Forming Part of Sentence 9.8.4.2.(1)

Stair Type	Rectangular Treads	
	Run, mm	
	Max.	Min.
Private <sup>(1)</sup>	355	255
Public <sup>(2)</sup>	No limit	280

**Notes to Table 9.8.4.2.:**

- (1) Private stairs are exterior and interior stairs that serve
  - (a) single dwelling units,
  - (b) houses with a secondary suite including their common spaces, or
  - (c) garages that serve a) or b).
- (2) Public stairs are all stairs not described as service stairs or private stairs.

Articles 9.8.4.1. to 9.8.4.8. specify various dimensional limits for steps. Figure A-9.8.4.-B illustrates the elements of a step and how these are to be measured.

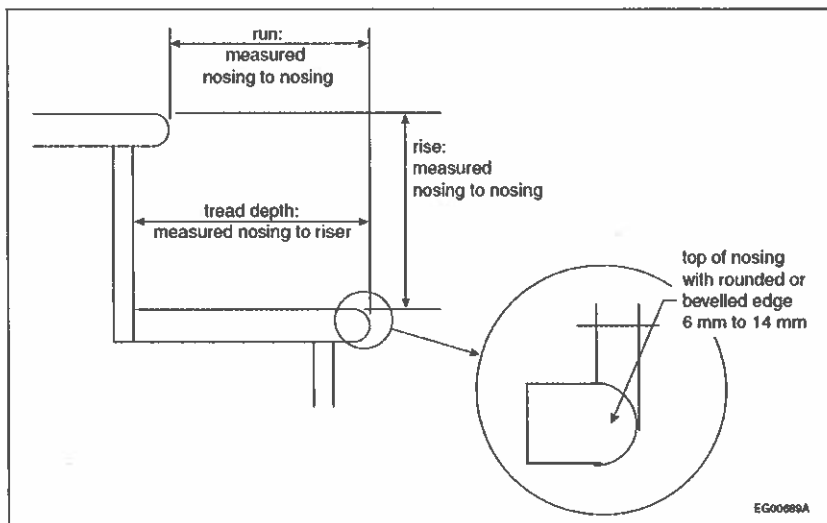

**Figure A-9.8.4.-B**  
 Elements of steps and their measurement

This Letter of Notice does not cover all requirements for building code compliant stairs, but highlights a notable change in code requirements. Stair dimensions including rise and run of stairs will be required when applying for a building permit that includes the construction of stairs. We hope this letter of notice will help eliminate confusion about stair requirements and encourage uniform application of the 2015 NBCC requirements for stairs throughout Whitehorse. Your assistance in achieving this goal is greatly appreciated.

Matthew Wilkinson  
 Supervisor, Building Inspections  
 Land and Building Services  
 City of Whitehorse