

CLASS 'A' BEDDING

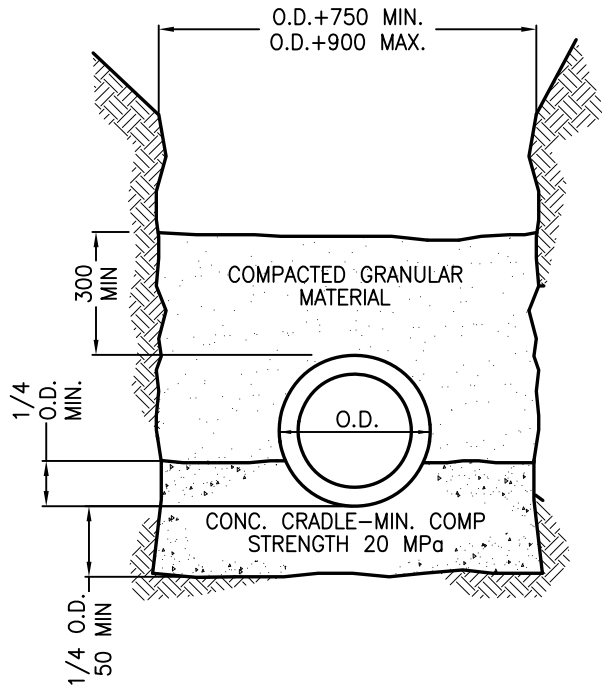

CLASS 'B' BEDDING

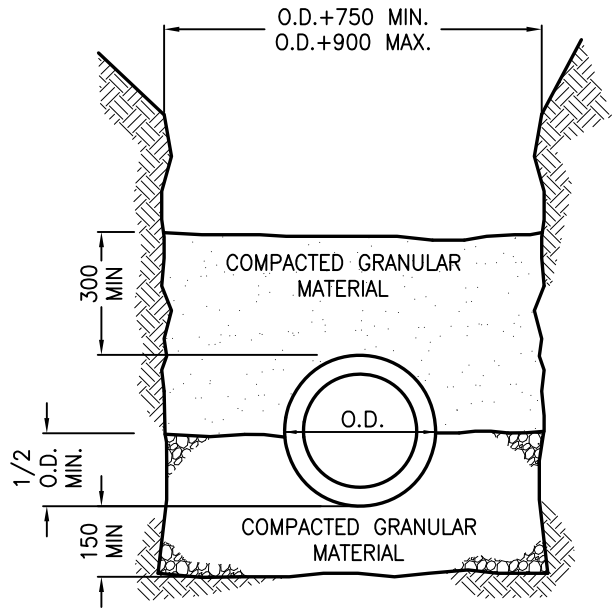

NOTE:

1. COMPACTION OF BEDDING AND PIPE ZONE BACKFILL SHALL BE AS PER SPECIFICATIONS. (MIN. 95% S.P.D.)
2. ALL DIMENSIONS ARE GIVEN IN MILLIMETRES

CLASS 'C' BEDDING

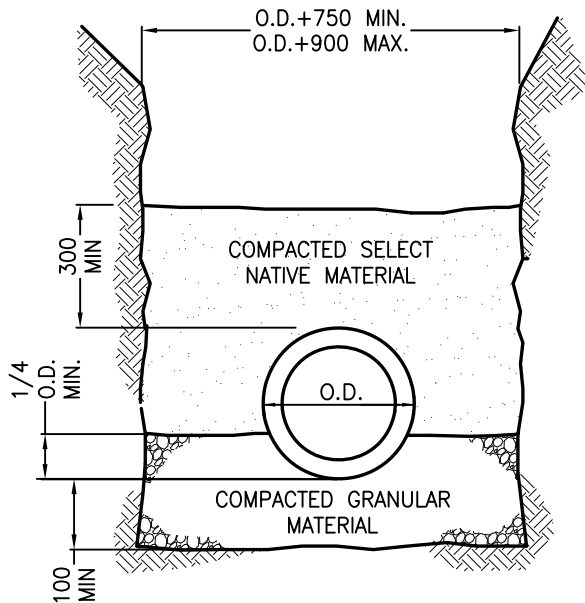

CLASS 'D' BEDDING

